

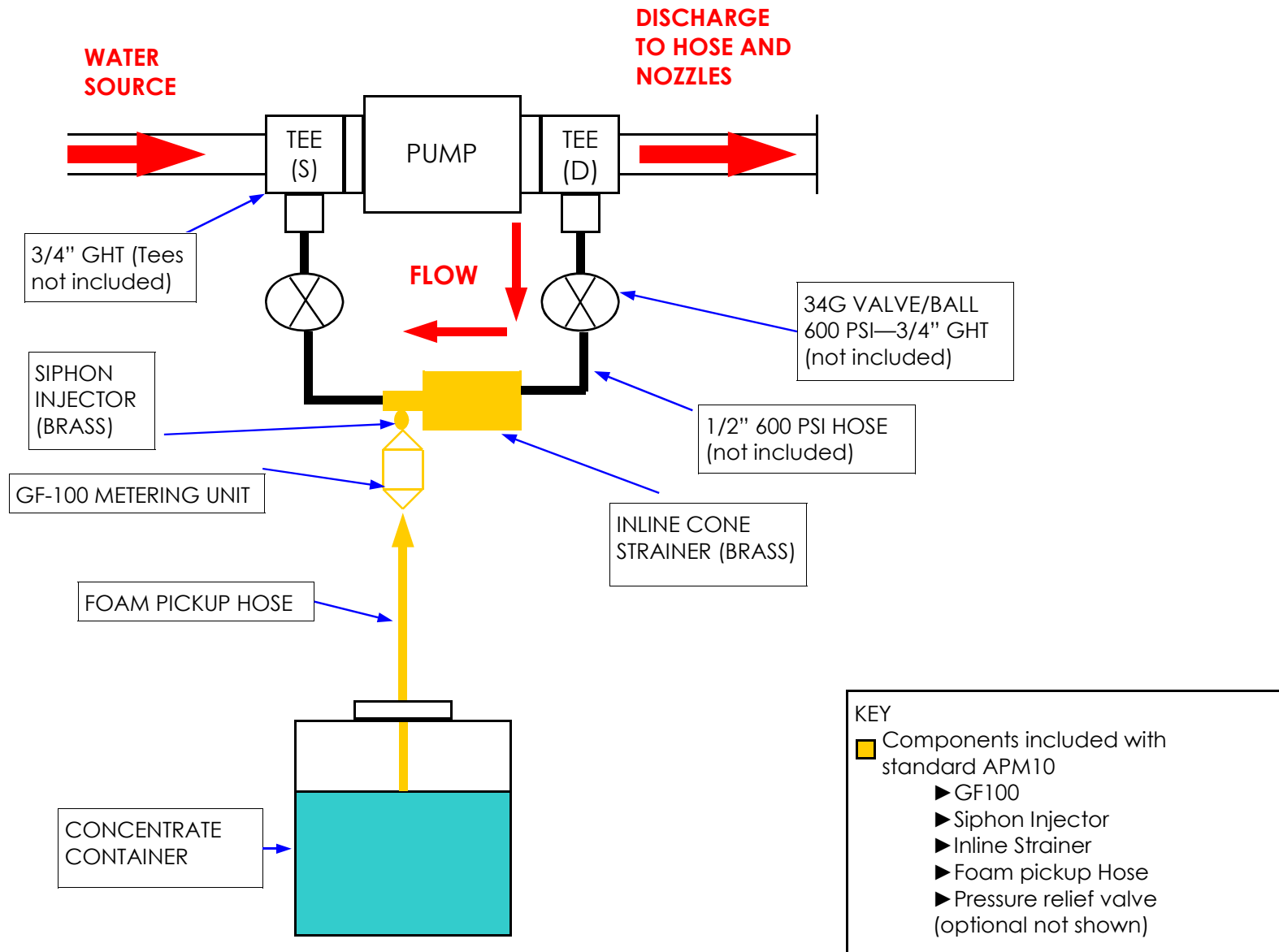

TYPE ONE INCIDENT SUPPORT LLC
PO BOX 8209, BEND, OREGON 97708-8209, USA
T 541-330-4340 F 541-330-4341

- PRODUCT: AROUND THE PUMP METERING SYSTEM – APM10
- PURPOSE: To provide a simple and directly manageable ability to inject wildland foams at the suction side of the pump. Where net positive suction head (NPSH) exists due to pump location and/or tank configuration.
- APPLICATIONS:
- Portable Pumps and Tanks
 - Engines (PTO or otherwise) where NPSH exists
- FEATURES/BENEFITS:
- Injection and mixing at low flows
 - Internal check valve and shutoff
 - Six positive settings with manual control
 - Efficient/remote location in respect to pump
 - Ease of maintenance and access
 - Removable for maintenance or other uses
 - Industrial quality components
- COMPONENT COMPOSITION:
- GF-100 Metering Unit
 - Customer supplied discharge tee
 - Strainer; inline cone (brass)
 - Mounting bracket assembly

SEE THE FOLLOWING DIAGRAM



AROUND THE PUMP METERING SYSTEM—APM10

TYPE ONE INCIDENT SUPPORT LLC, PO BOX 8209, BEND, OREGON 97708-8209 • T 541-330-4340 • F 541-330-4341